



## Technical data

### 6305NC3

Single row deep groove ball bearings

Deep groove ball bearing, radial contact, pressed steel cage, snap ring groove on outer diameter, open

#### VISUAL (S)

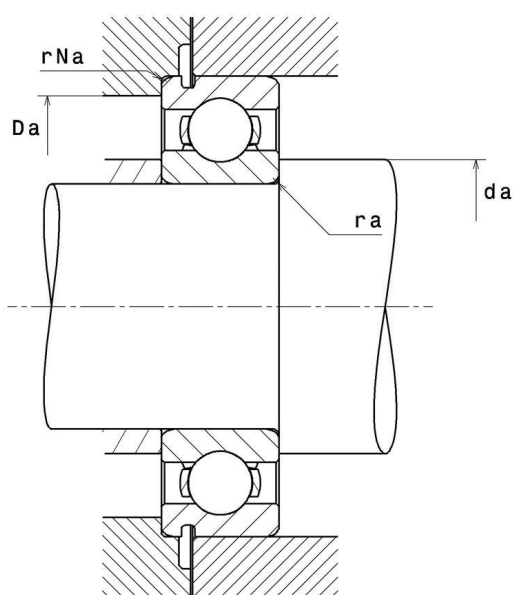
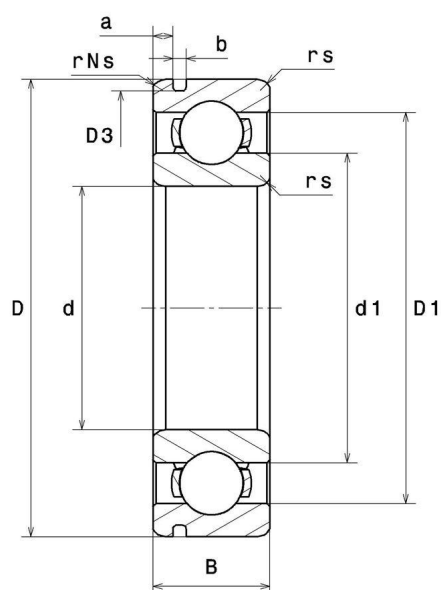

# 6305NC3

Single row deep groove ball bearings

## PRODUCT DIMENSIONS

<b>d - Internal diameter</b>	25 mm
<b>D - External diameter</b>	62 mm
<b>B - Bearing/Inner ring width</b>	17 mm
<b>a min - Min position Groove</b>	3.07 mm
<b>a max - Max position groove</b>	3.28 mm
<b>rs - Min fillet radius</b>	1.1 mm
<b>rNs - Min fillet radius</b>	0.5 mm
<b>D3 - Max bottom groove diameter</b>	59.61 mm
<b>b min - Min groove width</b>	1.9 mm
<b>b max - Max groove width</b>	2.2 mm
<b>r0 max - Max bottom groove radius</b>	0.6 mm
<b>Radial clearance class</b>	C3
<b>Mass</b>	0.232 kg
<b>Brand</b>	NTN

## PRODUCT PERFORMANCE

<b>C - Dynamic load</b>	23.5 kN
<b>C0 - Static load</b>	10.9 kN
<b>Cu - Fatigue limit load</b>	0.855 kN
<b>f0 - Coefficient</b>	12.6
<b>Nlim - Oil lubrication limit speed</b>	14000 tr/min
<b>Nlim - Grease lubrication limit speed</b>	12000 tr/min
<b>Tmin - Min operating temperature</b>	-40 °C
<b>Tmax - Max operating temperature</b>	120 °C

# 6305NC3

Single row deep groove ball bearings

## ABUTMENT

<b>da min - Min shoulder diameter IR</b>	31.5 mm
<b>Da max - Max shoulder diameter OR</b>	55.5 mm
<b>ra max - Max shaft &amp; housing fillet radius</b>	1 mm
<b>rNa max - Max fillet radius on segment side</b>	0.5 mm

## INDUSTRY CALCUL FACTORS

Equivalent dynamic radial load

$$P = X.F_r + Y.F_a$$

$\frac{f_0 F_a}{C_0}$	e	Fa / Fr ≤ e		Fa / Fr > e	
		X	Y	X	Y
0.172	0.19	1	0	0.56	2.3
0.345	0.22				1.99
0.689	0.26				1.71
1.03	0.28				1.55
1.38	0.3				1.45
2.07	0.34				1.31
3.45	0.38				1.15
5.17	0.42				1.04
6.89	0.44				1

Equivalent static radial load

$$P_0 = X_0.F_r + Y_0.F_a$$

$X_0$	$Y_0$
0.6	0.5

For single or DT bearing arrangement:

If  $P_0 < F_r$ , then use  $P_0 = F_r$